

MODEL 500 LOADER SPECIFICATIONS

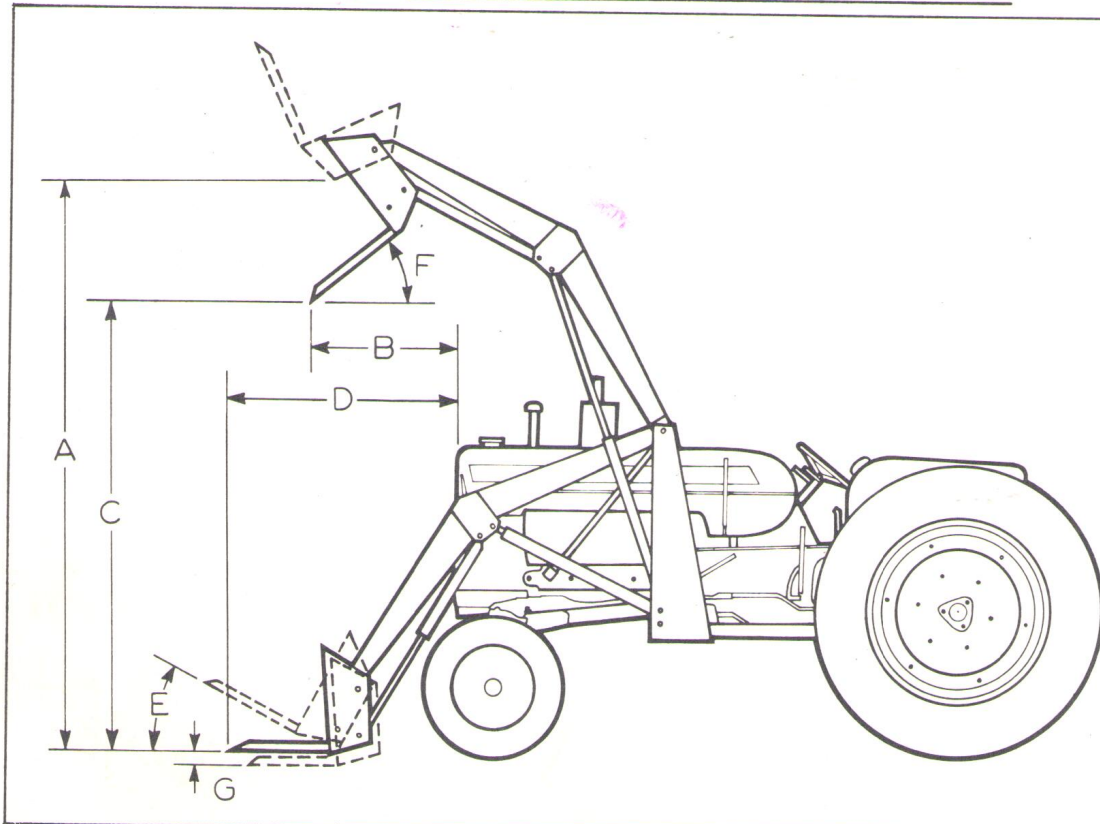

MANURE BUCKET

Width	42"	60"	72"
Height	27"	27"	27"
Length	37"	37"	37"
Capacity Heaped	8 cu. ft.	11 cu. ft.	13 cu. ft.

MATERIAL BUCKET

Width	42"	60"	80"
Cu. Ft. Capacity	10-3/4	17-1/2	23.65

	TRACTORS		
	D-17	D-17IV	D-19
Lifting Capacity @ Full Height	2300	2300	2300
Carrying Capacity @ 3 Ft. Height	3400	3400	3500
Breakaway Force	4000	4000	4000
Maximum Clearance @ Max. Height	A 126"	126"	127"
Reach @ Maximum Height	B 28"	28"	33"
Clearance, Bucket Dumped	C 97"	97"	98"
Clearance, Bucket @ Ground Level	D 56-1/2"	56-1/2"	58"
Bucket Rollback	E 30°	30°	30°
Maximum Dumping Angle	F 45°	45°	45°
Digging Depth Capacity	G 6"	6"	5"
Cycle Time, Up	5.0 Sec.	5.0 Sec.	5.5 Sec.
Cycle Time, Down	2.4 Sec.	2.4 Sec.	2.5 Sec.
Pump Capacity (GPM at RPM)	11 GPM.	11 GPM.	11 GPM.
	@ 1650 RPM	@ 1650 RPM	@ 2000 RPM
Separate Hydraulic Pump	Yes	No	Yes

The Allis-Chalmers Manufacturing Company reserves the right to make changes in the above specifications or to add improvements at any time without notice or obligation.